



HAM TIPS

PUBLISHED - IN - THE - INTEREST - OF - RADIO - AMATEURS - AND - EXPERIMENTERS

VOLUME VIII, No. 4

EDITORIAL OFFICES, RCA, HARRISON, N. J.

NOVEMBER—DECEMBER 1948

NEW PRACTICAL METHOD DEVELOPED FOR CURING TVI!

Holiday Greetings...

*our sincere wishes for you...
good health, much happiness
and abundant dx*



SIMPLIFYING THE CALCULATION OF TRANSMITTING TRIODE PERFORMANCE

By E. E. SPITZER
Power Tube Group
RCA Engineering Section

Simple methods of calculating transmitting triode performance are presented in this article which give results very close to published data. They are applicable to class C amplifiers both modulated and unmodulated and also to class B audio amplifiers.

Published data on transmitting tubes show many typical operating conditions which are excellent guides for the operation of the tubes. Conditions sometimes arise, however, which make other operating conditions desirable or necessary.

Many amateurs would probably like to calculate new tube operating conditions but are deterred by the apparently formidable mathematics involved. In this article, the mathematics for the calculations of class C amplifiers are very much boiled down by eliminating one variable, the length of the plate-current pulse. For our calculations, this variable is assumed to be 140 degrees of an rf cycle. 140 degrees is a representative value for class C amplifiers. With this assumption, five simple formulas permit calculation of power output, plate loss, grid bias, grid current, and driving power. The same method of calculation is extended to class B audio amplifiers by using a plate pulse of 180°. Several examples are worked out to show clearly how the methods are used.

In the method described here, the calculations are based on the in-

stantaneous values of grid and plate current at the peak of the plate-current pulse. It is well known that this peak occurs when the grid voltage is at its peak positive excursion and the plate voltage is at its peak negative excursion. When these two voltages are equal, the tube has very nearly its optimum performance. This important fact is recognized in the tube characteristic curves by the inclusion of a curve labeled $E_c = E_b$. The 812-A characteristic curves shown in Figure 5 include this limiting curve. If we choose a point such as "A" on the $E_c = E_b$ curve in Figure 5, we can read directly the instantaneous plate current, the required plate and grid voltages, and then, by dropping down to point "B" on the I_c family, we can also read the instantaneous grid current for the same grid voltage. All calculations are then made using these values.

Class C Operation (Telegraphy and Telephony)

It is assumed that we have data on the tube including the plate-characteristic curves. It is also assumed that we want to operate at a certain value of dc plate voltage,
(Continued on Page 3, Column 1)

REDUCING THE HARMONIC POWER OUTPUT OF AMATEUR TRANSMITTERS

By JOHN L. REINARTZ, W3RB
RCA Tube Department

Although it is not generally realized, most amateur transmitters using but one tuned circuit in the final output stage cannot meet the FCC rule stated in Article 17, Act of 1947 with regard to the reduction of the radiation of harmonic frequencies to not less than 40 db below the output of the fundamental frequency.

This article is the first of a series on harmonic reduction which will present some practical methods of minimizing TVI at the source.

Why We Have Harmonics

All tubes generate harmonic components when operated under class C conditions. Each time the grid of the tube is driven positive, a current pulse flows in the plate circuit of the tube. The current value for each of the harmonics produced depends on the angle of plate-current flow. For example, for a plate-current-flow angle of 140° the harmonic relationships¹ are given in Table I.

TABLE I

Component	Current, % of Fundamental	Equivalent Power level referred to Fundamental (db)
Fundamental	100	0
Second Harmonic	69.4	-3.2
Third Harmonic	30.8	-10.3
Fourth Harmonic	4.6	-25.8

The voltages produced across the output circuit by these harmonic components are dependent on the magnitude of the impedances presented to each harmonic component by the tuned circuit and are dependent to a large degree on the Q of the tuned circuit.

The performance of any amplifier in a transmitter is determined by both the characteristics of the associated tuned circuit and the tube. The choice of the tube has been made easy for us by the manufacturer who has supplied us with the necessary tube characteristics and operating values. It is, therefore, only necessary to consider the rf circuit constants that should be used. C, L, and R can be of various values within rather large limits, and, if frequency were the only consideration, the capacitance could be made small and the inductance large or vice versa. The action of the reflected load resistance on the tuned tank circuit is to decrease the sharpness of tuning as its shunt value is made smaller. In actual practice, however, there is a compromise value for the three components which results in high efficiency and good harmonic suppression.

Now, the larger the value of the tuning capacitor, the smaller the
(Continued on Page 2, Column 1)

EXPERIMENTAL MODEL

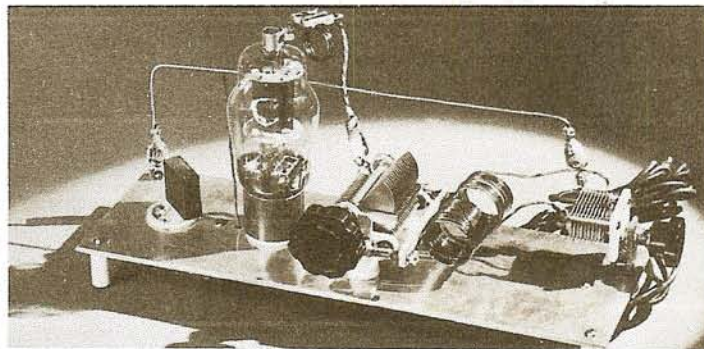

This one-stage rig was designed to reduce harmonic radiation and resultant television interference. Although it is not the unit described in HAM TIPS, it utilizes the same practical method discussed.

WHAT THE DOCTOR ORDERED

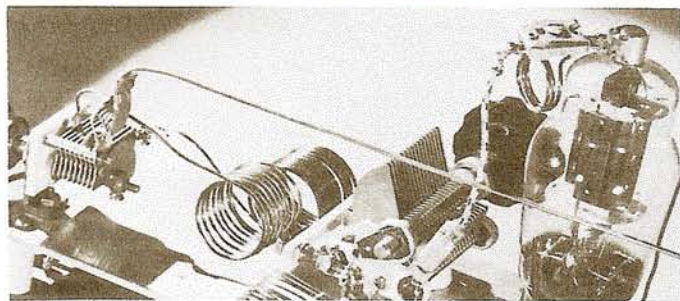

Component details which were found essential for reducing harmonic output are shown in this close-up. A plate shunt trap in upper right of photo reduces harmonic pulses generated at the plate of the 807. An absorption trap coil, center, tunes to the harmonic and changes the phase relation with respect to the plate tank tuning system. Cancellation of stray harmonic currents traversing the chassis is accomplished by means of a cancellation wire shown running parallel with chassis.

HARMONIC POWER OUTPUT

(Continued from Page 1, Column 4)

impedance it presents to the harmonic components in the plate-current pulse. Consequently, the harmonic voltage produced across this capacitor is smaller. In addition, there is a larger circulating current in a larger capacitance for a given power output. It is this ratio, called Q, of the circulating volt-amperes, (rf voltage times circulating current) to the power out-

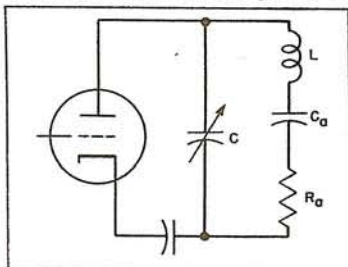

Figure 1. A single-tuned circuit.

put, that determines the harmonic power that can be passed on. The harmonic power is higher for low Q and lower for high-Q circuits.

Harmonics are suppressed to a considerable extent even by a simple tuned circuit.² For example, if the tuned tank circuit is as shown in Figure 1 where Ra and Ca are the antenna resistance and capacitance, then the db reduction of harmonics in the antenna due to the Q of the tank circuit is given in Table II.

TABLE II

HARMONIC REDUCTION in db DUE TO A SINGLE-TUNED CIRCUIT REFERRED TO FUNDAMENTAL-FREQUENCY POWER

Q	Second Harmonic	Third Harmonic	Fourth Harmonic
5	-23.5	-32.0	-37.5
10	-29.6	-38.1	-43.5
15	-33.0	-41.6	-47.0
20	-35.6	-44.1	-49.6

adding these values to those given in Table I gives—

TABLE III

HARMONIC POWER OUTPUT in db OF TUBE AND SINGLE-TUNED CIRCUIT REFERRED TO FUNDAMENTAL-FREQUENCY POWER

Q	Second Harmonic	Third Harmonic	Fourth Harmonic
5	-26.7	-42.3	-63.3
10	-32.8	-48.4	-69.3
15	-36.2	-51.9	-72.8
20	-38.8	-54.4	-75.4

We see from these tabulations that every time we double the Q of the tuned circuit the harmonic level goes down by 6 db. For the second harmonic, however, this reduction is still insufficient to comply with the FCC rule of -40 db even when the Q of the tuned circuit is 20.

Harmonic Suppression in Double-tuned Circuit

If the circuit is doubly tuned as in Figure 2, there is an even greater reduction in harmonics as shown in Table IV.

TABLE IV

HARMONIC REDUCTION in db DUE TO 2 COUPLED CIRCUITS REFERRED TO FUNDAMENTAL-FREQUENCY POWER

Q	Second Harmonic	Third Harmonic	Fourth Harmonic
5	-38.2	-54.4	-76.8
10	-50.2	-67.4	-88.8
15	-57.3	-75.1	-96.2
20	-62.3	-79.4	-100.8

It can be seen from this tabulation that whenever the value of Q is doubled the harmonics are all reduced by 12 db. Another important fact that can be deduced from these tables is that it is better to have a Q of say 10 in each tuned circuit of Figure 2 than to have a Q of 20 in the single tuned circuit of Figure 1. Now we can meet the FCC rule of -40 db for harmonic radiation if we use a Q of 10 or better in each of the tuned circuits. This -40-db value represents 0.01 watt for an amateur station radiating 100 watts at the fundamental frequency.

Field-Strength Considerations

Let us consider the field strength produced by an antenna. The field strength produced by a horizontal half-wave dipole³ is

$$E = 23 \frac{\sqrt{P}}{d} \text{ volts per meter,}$$

where P is the radiated power in watts and d is the distance in feet from the radiator to the point where E is measured. This value can be considered an average value. Actually, the field strength varies with distance between a lower and higher value because of subtraction and addition of the wave reflected from the ground and the direct wave, and also because the configuration of the lobes changes with the effective length of the transmitting antenna for any particular har-

monic. The formula is useful for distances up to about 650 feet. Since the amateur is concerned with distances within this value down to say 50 feet, the above formula for field strength applies. Inversion of the formula will give the power required to produce a given field strength.

$P = 1880 (Ed)^2$ microwatts, where E is in volts/meter and d is in feet.

The limiting field strength for the service area of a television transmitter is considered by the FCC to be 500 microvolts per meter in residential and rural areas. It has been determined that an interfering

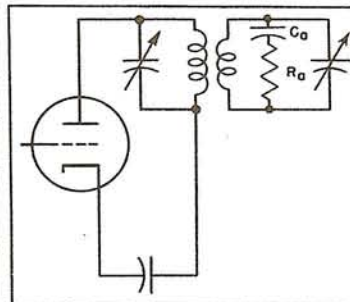

Figure 2. A double-tuned circuit.

signal of 1/100 this value is not objectionable. The amateur, therefore, should not produce an interfering field greater than 5 microvolts/meter for such a service area.

Let us now find the power required to produce such a field at 500 feet.

$$P = 1880 (5 \times 10^{-6} \times 500)^2 = 0.012 \text{ microwatts.}$$

Compare this 0.012-microwatt value with the 0.01 watt (10000 microwatts) which the present FCC rulings allow for harmonic radiation when the radiated fundamental output is 100 watts. A 0.01-microwatt value represents a power ratio of harmonic to fundamental values of 10^{-10} or -100 db when the power radiated at the fundamental is 100 watts. This changes to 10^{-11} or

CURING TVI

"Reduction of Harmonic Power Output in Amateur Transmitters" published in this issue of HAM TIPS is the first of a series of articles on this important subject by John L. Reinartz, W3RB, a member of the RCA Tube Department and one of the nation's best-known Radio Amateurs. In his next article Captain Reinartz will describe further his method of attack on TV interference.

-110 db when the fundamental power is 1000 watts. These values are far more severe than the -40 db level currently required, but are what the amateur must attain if he wants to stay on good terms with the general public.

Other Methods of Reducing TVI

Because even two tuned tank circuits may fail to reduce an interfering signal to the -100 or -110 db level, other means must be found. Several good articles on the subject have appeared in amateur magazines. Mack Seybold has shown in the August 1947 issue of QST that the addition of trap circuits in the plate lead of the final class C stage will reduce the harmonic level some 40 to 50 db and if considered along with two tuned tank circuits may reach the desired -100 or -110 db level.

Harmonic Suppression

In cases where even the processes outlined above fail to reduce the interference to television reception at distances shorter than 500 feet, it will be found advantageous to resort to additional grounded trap circuits tuned to the interfering harmonic. These trap circuits should be closely coupled to the hot end of each plate tank circuit of every stage in the transmitter. Such a system, devised by the writer, was found capable of apparently completely cancelling a harmonic. Because every rf stage in a transmitter amplifies the harmonic components present in its grid ex-

(Continued on Page 3, Column 3)

IN DOUBLER SERVICE EMISSION COUNTS

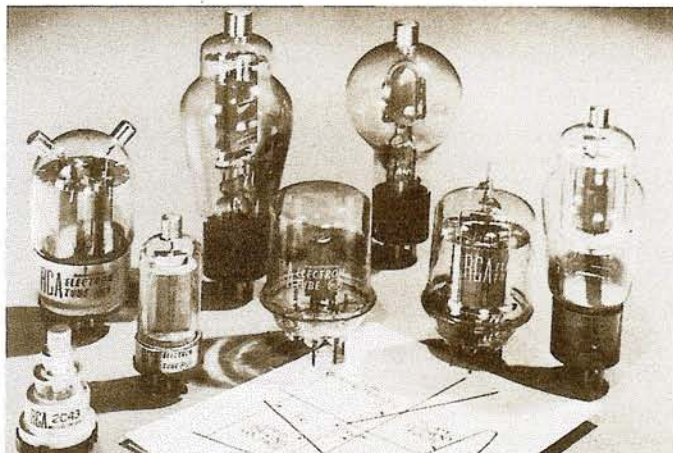

It takes a lot of cathode emission to back up heavy peak plate current pulses when driving a frequency-multiplier tube for optimum gain. That's why RCA high-transconductance beam power tubes are preferred types for medium-power doubler and tripler service. They produce maximum plate-current swing for a given grid signal voltage. And they have the high-power filaments and heater-cathodes required to handle high peak plate-current . . . with emission to spare.

SIMPLIFIED CALCULATIONS

(Continued from Page 1, Column 2)

E_b , and with a certain average plate current, I_b . We want to know power output, P_o , grid bias, E_c , dc grid current, I_c , and driving power, P_d .

First we find the peak plate current. This value is 4 times the average plate current, I_b . Then, we go to the plate-characteristic curves and on the curve $E_c = E_b$, we find the instantaneous plate voltage e_b , and the instantaneous grid voltage e_c , at which we get the plate current of $4 I_b$. With these values, together with the amplification factor, μ , obtained from the tube data, we then apply the following formulas.

Power output

$$P_o = 0.86 (E_b - e_b) I_b \text{ (watts)} \quad (1)$$

Plate loss

$$P_p = E_b I_b - P_o \text{ (watts)} \quad (2)$$

Grid bias

$$E_c = \left[\frac{E_b}{\mu} + 0.52 \left(\frac{\mu + 1}{\mu} \right) e_b \right] \text{ (volts)} \quad (3)$$

Peak rf driving voltage

$$e_g = E_c + e_c \text{ (volts)} \quad (4)$$

To get the dc grid current, I_c , we first have to calculate $\frac{E_c}{e_g}$ the ratio of the grid bias to the peak rf driving voltage and then from Figure 4 get $\frac{I_c}{i_c}$ the ratio of average grid current to the instantaneous grid current at $E_c = E_b$. The instantaneous grid current is obtained from the characteristic curves.

Then, the average grid current, $I_c = i_c \times$ (ratio $\frac{I_c}{i_c}$ from Figure 4), (amperes) (5)

and driving power

$$P_d = 0.9 \times e_g \times I_c \text{ (watts)} \quad (6)$$

The calculated power output figure as well as the published typical power output values are theoretical values of tube output which include both useful output and rf losses in the tube, in the tank circuit, and associated wiring. Useful rf power obtainable, therefore, will depend on the efficiency of the circuit and in turn upon the quality of components and circuit layout used.

The calculated value of driving power includes only the actual power input to the grid plus the power lost in the bias supply. It

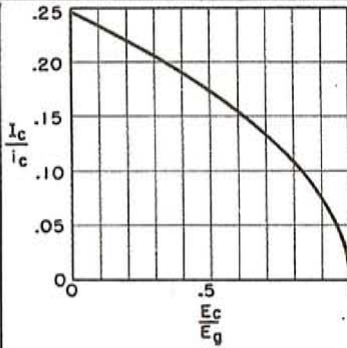

Figure 4. Curve from which ratio of $\frac{I_c}{i_c}$ is obtained.

does not include rf losses that occur in the driver-stage tank circuit, in coupling from the driver stage, in the socket and wiring or losses in tubes caused by transit-time loading. The driver stage power output, therefore, should be substantially greater than the calculated value of driving power in order to provide an adequate range of adjustment for optimum transmitter performance.

Example

As a check, this method may be applied to the 1500-volt ICAS Telegraphy condition given in the published data for the 812-A (Figure 6 on page 4). The given conditions are $E_b = 1500$ volts, $I_b = 173$ ma., $\mu = 29$. The peak plate current is $4 \times 173 = 692$ ma. This value of current can be obtained at $e_c = e_b = 120$ volts, as given in the plate characteristics, Figure 5, at point A.

Power output

$$P_o = 0.86 (1500 - 120) 0.173 = 205 \text{ watts}$$

$$\text{Plate loss } P_p = 1500 \times 0.173 - 205 = 259 - 205 = 54 \text{ watts}$$

Grid bias

$$E_c = - \left[\frac{1500}{29} + 0.52 \left(\frac{30}{29} \right) 120 \right] = -116 \text{ volts}$$

Peak rf driving voltage

$$e_g = 116 + 120 = 236 \text{ volts}$$

$$\text{and } \frac{E_c}{e_g} = \frac{116}{236} = 0.49$$

$$\text{From Figure 4, } \frac{I_c}{i_c} = 0.175$$

From the characteristic curves (Figure 5) for $e_c = e_b = 120$ volts, $i_c = 220$ ma. or 0.220 amp. at point "B".

(Continued on Page 4, Column 1)

FOUNTAINHEAD OF TUBE INFORMATION

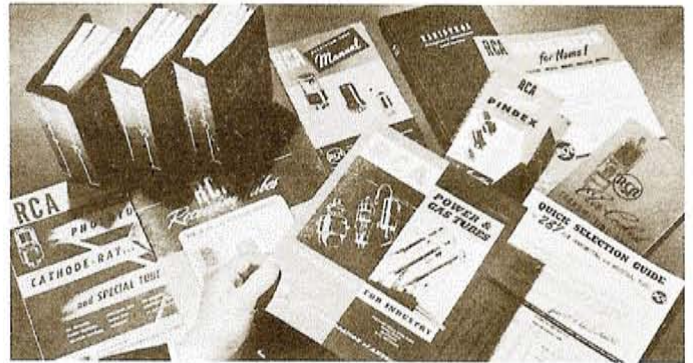

Amateurs everywhere look to RCA tube publications for accurate data and unquestioned authoritativeness. For information on the material shown, see your local RCA Distributor, or write Commercial Engineering, RCA, Harrison, N. J.

HARMONIC POWER OUTPUT

(Continued from Page 2, Column 4)

citation voltage, the first place to get rid of the harmonic is at the crystal oscillator plate-tank circuit. What may be left can be taken care of in subsequent stages at their respective plate tank circuits.

To prove the effectiveness of this system, a 2E26 oscillator-doubler, controlled by a 7-Mc crystal, followed by an 813 final was built having the shunt traps roughly tuned to 28 Mc and the grounded traps (tuned to the offending harmonic, approx. 28 Mc) coupled closely to each plate tank circuit.

In some cases, it may be necessary to tune one or more of these traps to the third harmonic, to obtain greater reduction of interference.

The essentials of this circuit are shown in Figure 3. A television receiver was set up ten feet away and connected to a standard 90" folded-dipole antenna through 100' of 300-ohm, twin-lead transmission line. The antenna for the transmitter was strung within 8 feet of the TVR antenna. With normal excitation to the 813 tube in the 20-meter band and with the TVR tuned to channel 2, it was possible to operate the transmitter with 100% 60-cycle modulation without undue interference to the TVR even though the transmitter was incompletely shielded in that the entire top cover of the transmitter cabinet was removed. The measured output from the 813 was adjusted to 150

watts as a convenient value for testing purposes.

A cathode-ray oscilloscope was connected to the grid circuit of the receiver kinescope to allow further visual indication of the interference caused by the transmitter when the closely coupled grounded-trap circuits were detuned. Under such conditions the pattern on the kinescope was a maze of interference and the CRO tube showed a pattern with both rf and 60-cycle components present at the grid of the kinescope. All these patterns disappeared when the grounded plate traps were properly tuned. The shunt traps in series with the plate circuits of the two tubes needed only to be tuned to the inductive side of resonance of the unwanted harmonic. This tuning was not critical. To obtain the results described, the grounded-trap coil should be located at the hot end of the tank coil and wound on the same form and in the same direction. Ground the trap coil at the far end, away from the tank coil.

It is realized that a complete test requires that the TVR be tuned to a television station signal in order to determine if any interference may still be present that could not be detected under the test conditions outlined above. Such tests are underway and will be discussed in the next article of this series.

¹Radio Engineers Handbook, FE Terman, Fig. 86
²"L-bus and Reder", Proc. IRE., Vol. 19, pp 949-962, 1931
³RMA publication R4-2860-A (July 1948) by W. T. Winttingham.

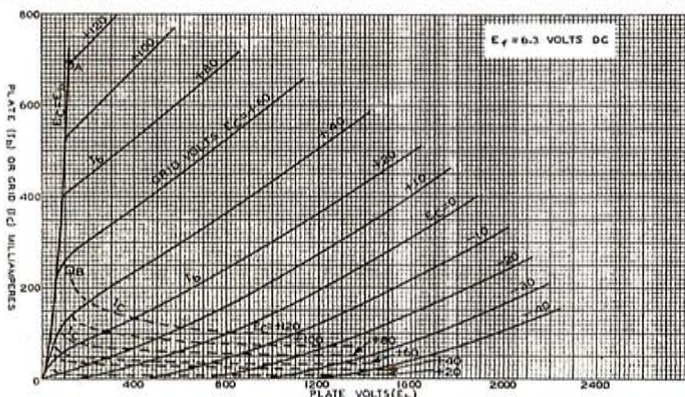

Figure 5. The 812-A characteristic curves.

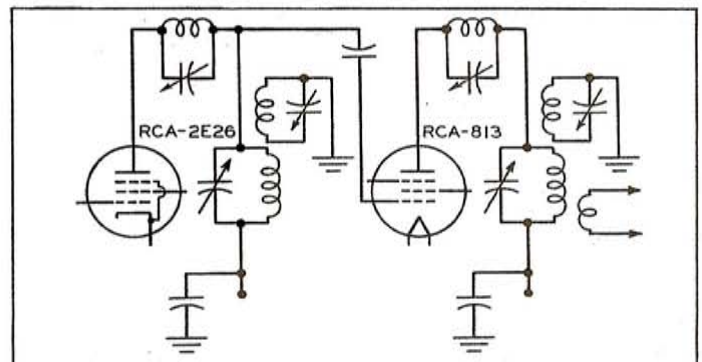

Figure 3. Schematic of method devised to cancel transmitter harmonics.

AF POWER AMPLIFIER & MODULATOR—Class B

Maximum Ratings, Absolute Values:

	CCS	ICAS	
DC PLATE VOLTAGE.....	1250 max.	1500 max.	volts
MAX.-SIGNAL DC PLATE CURRENT*.....	175 max.	175 max.	ma
MAX.-SIGNAL DC PLATE INPUT*.....	165 max.	235 max.	watts
PLATE DISSIPATION*.....	45 max.	65 max.	watts

Typical Operation:

Values are for 2 tubes

DC Plate Voltage.....	1250	1500	volts
DC Grid Voltage#.....	-40	-48	volts
Peak AF Grid-to-Grid Voltage.....	225	270	volts
Zero-Signal DC Plate Current.....	22	28	ma
Max.-Signal DC Plate Current.....	260	310	ma
Effective Load Resistance (plate-to-plate).....	12200	13200	ohms
Max.-Signal Driving Power (Approx.).....	3.5	5	watts
Max.-Signal Power Output (Approx.).....	235	340	watts

PLATE-MODULATED RF POWER AMP.—Class C Telephony

Carrier conditions per tube for use with a max. modulation factor of 1.0

Maximum Ratings, Absolute Values:

	CCS	ICAS	
DC PLATE VOLTAGE.....	1000 max.	1250 max.	volts
DC GRID VOLTAGE.....	-200 max.	-200 max.	volts
DC PLATE CURRENT.....	125 max.	150 max.	ma
DC GRID CURRENT.....	35 max.	35 max.	ma
PLATE INPUT.....	115 max.	175 max.	watts
PLATE DISSIPATION.....	30 max.	45 max.	watts

* Averaged over any audio-frequency cycle of sine-wave form.

Grid voltages are given with respect to the mid-point of filament operated on ac. If dc is used, each stated value of grid voltage should be reduced by one-half the filament voltage and the circuit returns made to the negative end of the filament.

Modulation essentially negative may be used if the positive peak of the audio-frequency envelope does not exceed 115% of the carrier conditions.

Figure 6. General data for the 812-A.

Typical Operation:

DC Plate Voltage.....	1000	1250	volts
DC Grid Voltage.....	-110	-115	volts
From a grid resistor of.....	3400	3300	ohms
Peak RF Grid Voltage.....	220	240	volts
DC Plate Current.....	115	140	ma
DC Grid Current (Approx.).....	33	35	ma
Driving Power (Approx.).....	6.6	7.6	watts
Power Output (Approx.).....	85	130	watts

RF POWER AMPLIFIER & OSC.—Class C Telegraphy

Key-down conditions per tube without modulation # #

Maximum Ratings, Absolute Values:

	CCS	ICAS	
DC PLATE VOLTAGE.....	1250 max.	1500 max.	volts
DC GRID VOLTAGE.....	-200 max.	-200 max.	volts
DC PLATE CURRENT.....	175 max.	175 max.	ma
DC GRID CURRENT.....	35 max.	35 max.	ma
PLATE INPUT.....	175 max.	260 max.	watts
PLATE DISSIPATION.....	45 max.	65 max.	watts

Typical Operation:

DC Plate Voltage.....	1250	1500	volts
DC Grid Voltage.....	-90	-120	volts
From a fixed resistor of.....	3000	4000	ohms
From a cathode resistor of.....	530	590	ohms
Peak RF Grid Voltage.....	200	240	volts
DC Plate Current.....	140	173	ma
DC Grid Current (Approx.).....	30	30	ma
Driving Power (Approx.).....	5.4	6.5	watts
Power Output (Approx.).....	130	190	watts

SIMPLIFIED CALCULATIONS

(Continued from Page 3, Column 2)

Therefore, the average grid current $I_c = 0.220 \times 0.175 = 0.038$ amperes and the driving power

$$P_d = 0.9 \times 236 \times 0.038 = 8.0 \text{ watts}$$

A comparison between these calculated values and the published data for the 812-A is shown in Table 1 below.

It can be seen from this comparison that for practical purposes there is a satisfactory agreement between published and calculated values.

Class B Operation (Audio Frequency)

For class B audio operation it may be assumed E_b and I_b are given. In this case, I_b is the plate current for both tubes of the push-pull amplifier.

TABLE 1. (class C)

	Calculated Values	Published Data
DC Plate Voltage (E_b).....	1500	1500 volts
DC Grid Voltage (E_c).....	-116	-120 volts
Peak RF Grid Voltage (e_g).....	236	240 volts
DC Plate Current (I_b).....	173	173 ma.
DC Grid Current (I_c).....	38	30 ma.
Driving Power (P_d).....	8.0	6.5 watts
Power Output (P_o).....	205	190 watts

Then, peak plate current for two tubes $I_b = 1.57 I_b$ (7)

At the value of I_b given by (7) we determine the peak grid voltage e_c and the peak plate voltage e_b on the $E_c = E_b$ curve.

The following formulas apply:

Power output for two tubes, $P_o = 0.78 (E_b - e_b) I_b$ (watts) (8)

Plate loss per tube, $P_p = \frac{1}{2} (E_b I_b - P_o)$ (watts) (9)

The grid bias should be chosen so that at E_b , a zero-signal current flows which produces a plate dissipation of about $\frac{1}{3}$ the rated dissipation. Thus, if each tube is rated to dissipate P_p watts,

Zero-signal plate current for two tubes $I_b' = \frac{2P_p'}{3E_b}$ (amperes) (10)

The bias required for this plate current can be found from the characteristic curves. The peak grid drive per tube is then the sum of the bias and $e_c (=e_b)$ which was determined for equation (8).

Peak grid-to-grid driving voltage $= e_g = 2(e_c + E_c)$ (volts) (11)

The required plate-to-plate load resistance

$$R_L = \frac{2.6 (E_b - e_b)}{I_b} \text{ (ohms)} \quad (12)$$

The maximum-signal driving power for two tubes,

$$W_d = \frac{i_c e_g}{4} \text{ (watts)} \quad (13)$$

where i_c is the grid current in amperes at the point found for equation (8).

Example

Again consider the typical operating conditions given in the published data for the 812-A as a class B AF power amplifier in ICAS service. The data given are $E_b = 1500V$, $I_b = 310$ ma. or 0.310 amperes (2 tubes).

Then the peak plate current $I_b = 1.57 \times 310 = 487$ ma.

From the $E_c = E_b$ curve in Figure 5 we get 487 ma. at $e_c = 90$ volts and $e_b = 90$ volts.

Then from equations (8), (9), and (10), power output for two tubes $P_o = 0.78 (1500 - 90) 0.310 = 340$ watts. Plate loss per tube

$$P_p = \frac{1}{2} (1500 \times 0.310 - 340) = 62.5 \text{ watts. Zero-signal plate current for two tubes}$$

$$I_b' = \frac{2 \times 65}{3 \times 1500} = 0.029 \text{ amperes.}$$

The required bias for a plate current (per tube) of 14.5 ma. at 1500 volts can be found from Figure 5 and is about -48 volts.

Then from equation (11),

$$\text{Peak grid-to-grid driving voltage } e_g = 2(90 + 48) = 276 \text{ volts.}$$

From equation (12), plate-to-plate load resistance $R_L =$

$$\frac{2.6 \times (1500 - 90)}{0.310} = 11,800 \text{ ohms}$$

To get the driving power, we first need the peak grid current at $e_c = e_b = 90$ volts. This value is obtained from Figure 5 and is 130 ma. or 0.130 amperes. Then, driving power for two tubes

$$P_d = \frac{0.130 \times 276}{4} = 9 \text{ watts.}$$

The calculated values may now be compared with the 812-A published data, as shown in Table 2 below.

Again, the approximate calculations give results in good agreement with the published data.

¹For a derivation of these formulas, refer to "Simplified Methods for Computing Performance of Transmitting Tubes", W. G. Wagener, Proc. IRE., Vol. 25, No. 1, January 1937, pp 47-77.

TABLE 2. (class B audio)

	Calculated Values	Published Data
DC Plate Voltage (E_b).....	1500	1500 volts
DC Grid Voltage (E_c).....	-48	-48 volts
Peak AF Grid-to-Grid Voltage (e_g).....	276	270 volts
Zero-Signal DC Plate Current (I_b').....	29	28 ma.
Max.-Signal DC Plate Current (I_b).....	310	310 ma.
Effective Load Resistance (Plate to Plate) (R_L).....	11,800	13,200 ohms
Max.-Signal Driving Power (P_d).....	9	5 watts
Max.-Signal Power Output (P_o).....	340	340 watts

HAM TIPS is published by the RCA Tube Department, Harrison, N. J., and is made available to Amateurs and Radio Experimenters through RCA tube and parts distributors.
H. S. STAMM, W2WCT Editor
JOHN L. REINARTZ, W3RB Technical Adviser



Devices and arrangements shown or described herein may use patents of RCA or others. Information contained herein is furnished without responsibility by RCA for its use and without prejudice to RCA's patent rights.

Parker Parker 7 Parker medium
Parker Parker 7 Parker medium